

**Features**

- 120Watts peak pulse power ( $t_p = 8/20\mu s$ )
- Tiny DFN0603 package
- Bidirectional configurations
- Solid-state silicon-avalanche technology
- Low clamping voltage
- Low leakage current
- IEC 61000-4-2  $\pm 30kV$  contact  $\pm 30kV$  air
- IEC 61000-4-4 (EFT) 40A (5/50ns)
- IEC 61000-4-5 (Lightning) 12A (8/20 $\mu s$ )

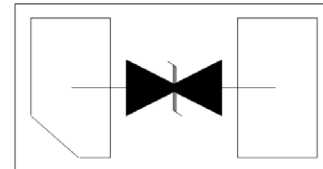
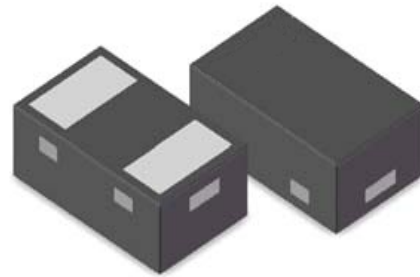

**DFN0603**

**Applications**

- Cell Phone Handsets and Accessories
- Microprocessor based equipment
- Personal Digital Assistants (PDA's)
- Notebooks, Desktops, and Servers
- Portable Instrumentation

**Mechanical Data**

- DFN0603 package
- Molding compound flammability rating: UL 94V-0
- Packaging: Tape and Reel
- RoHS/WEEE Compliant

**Electrical Parameters (TA = 25 °C unless otherwise noted)**

Symbol	Parameter
$I_{PP}$	Maximum Reverse Peak Pulse Current
$V_C$	Clamping Voltage @ $I_{PP}$
$V_{RWM}$	Working Peak Reverse Voltage
$I_R$	Maximum Reverse Leakage Current @ $V_{RWM}$
$V_{BR}$	Breakdown Voltage @ $I_T$
$I_T$	Test Current

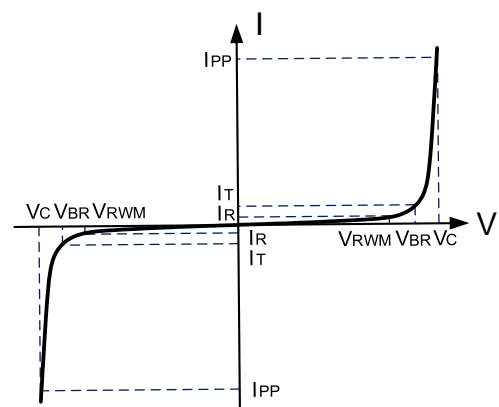

Note: 8/20 $\mu s$  pulse waveform.



### Absolute Maximum Rating

Rating	Symbol	Value	Units
Peak Pulse Power ( $t_p = 8/20\mu s$ )	$P_{PP}$	120	Watts
Peak Pulse Current ( $t_p = 8/20\mu s$ ) (note1)	$I_{pp}$	12	A
ESD per IEC 61000-4-2 (Air) ESD per IEC 61000-4-2 (Contact)	$V_{ESD}$	30 30	kV
Lead Soldering Temperature	$T_L$	260(10seconds)	°C
Junction Temperature	$T_J$	-55 to + 125	°C
Storage Temperature	$T_{stg}$	-55 to + 125	°C

### Electrical Characteristics

PART NUMBER	DEVICE MARKING	$V_{RWM}$	$V_B$		$I_T$	$I_R$		$C_T$	
		(V) (max.)	(min.)	(max.)	(mA)	( $\mu A$ ) (typ.)	(max.)	(typ.)	(max.)
RHTVSBC0321-T	E	3.3	3.75	4.95	1	0.01	0.5	15	18
		$V_C(8/20\mu s)$ (@1A) (typ.)   (max.)		$V_C(8/20\mu s)$ (@5A) (typ.)   (max.)		$V_C(8/20\mu s)$ (@7A) (typ.)   (max.)		$V_C(8/20\mu s)$ (@12A) (typ.)   (max.)	
		5.4	6	6	7	6.7	8	8.5	10
		$V_C(TLP)$ (@1A) (typ.)		$V_C(TLP)$ (@5A) (typ.)		$V_C(TLP)$ (@8A) (typ.)		$V_C(TLP)$ (@16A) (typ.)	
		4.7	6	5.7	7.5				



Typical Characteristics

Figure 1. 8 x 20  $\mu$ s Waveform

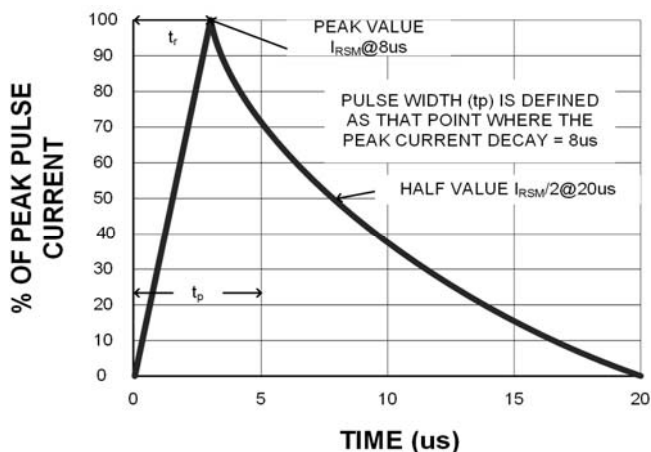

Figure 2. Power Derating Curve

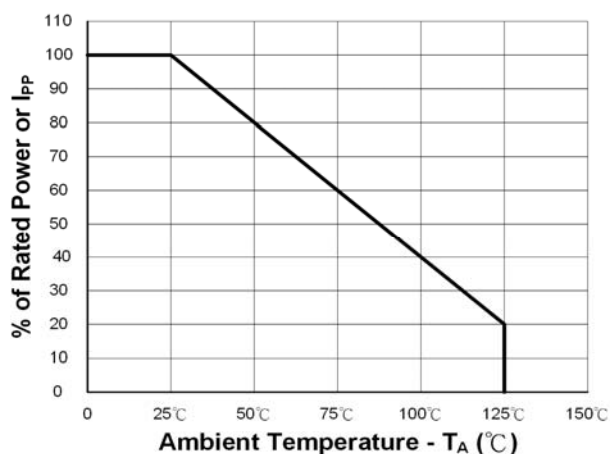
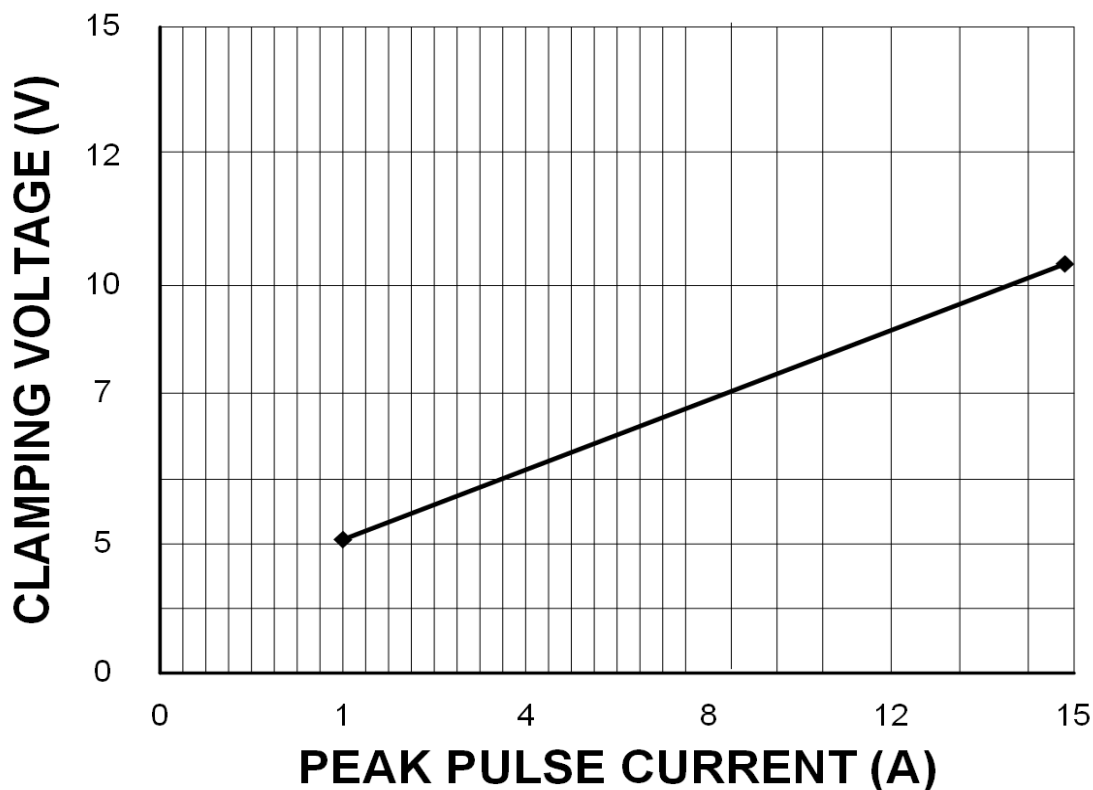

Figure 3. Clamping Voltage vs. Peak Pulse Current ( $t_p=8/20 \mu$ s)





# I-V Curve

## ◆ Condition 1

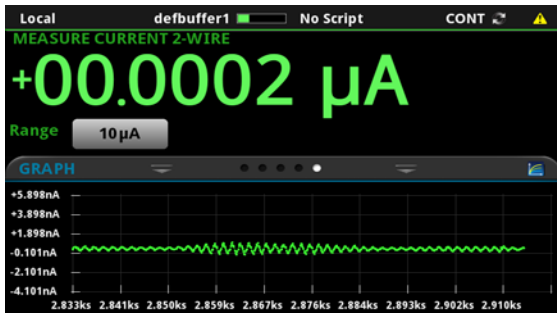

Pin 1 to 2, Bias=3.3V

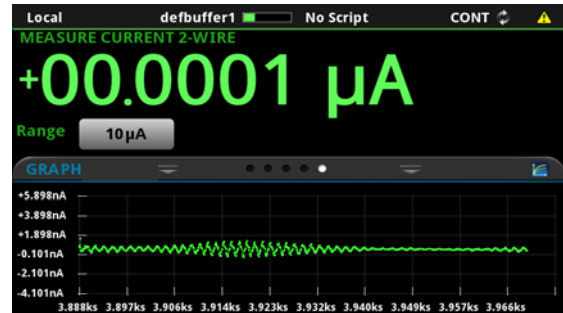

Pin 2 to 1, Bias=3.3V

## ◆ Condition 2

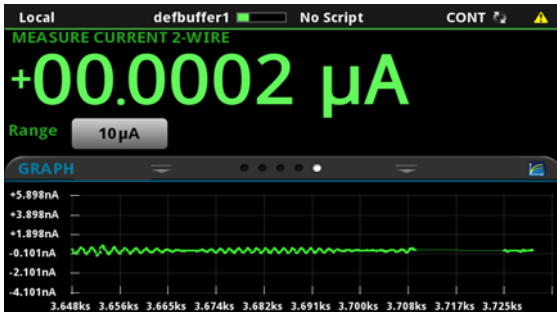

Pin 1 to 2, Bias=3.4V

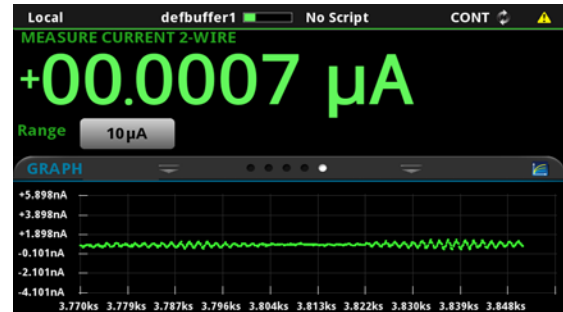

Pin 2 to 1, Bias=3.4V

## ◆ Condition 3

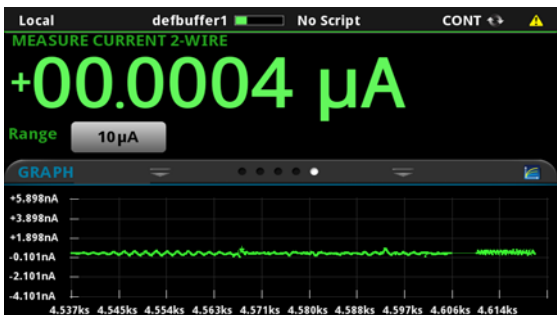

Pin 1 to 2, Bias=3.5V

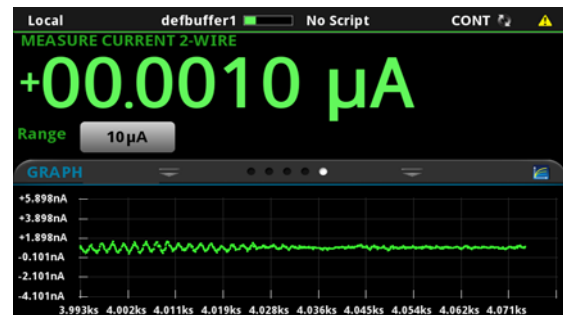

Pin 2 to 1, Bias=3.5V



# I-V Curve

## ◆ Condition 4

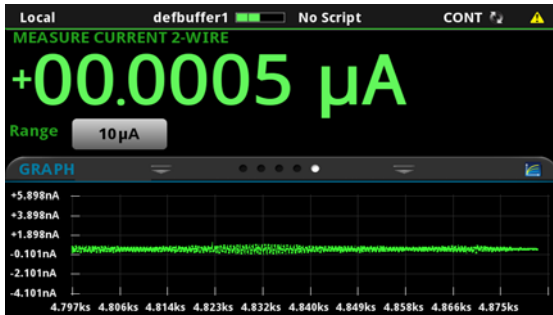

Pin 1 to 2, Bias=3.6V

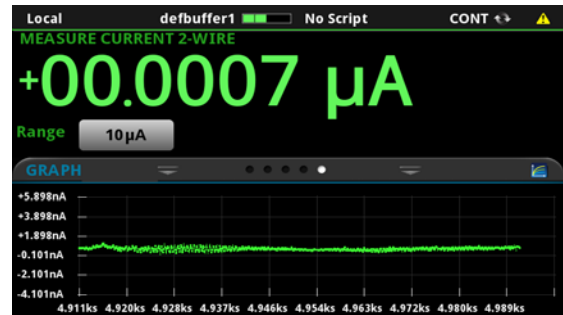

Pin 2 to 1, Bias=3.6V

## ◆ Condition 5

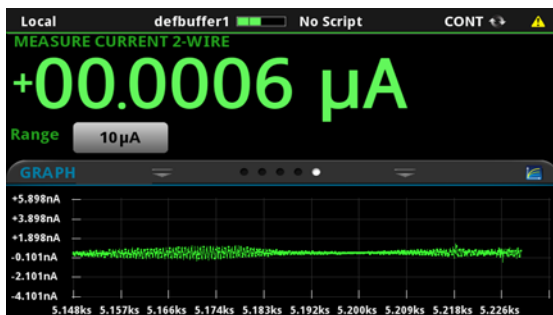

Pin 1 to 2, Bias=3.7V

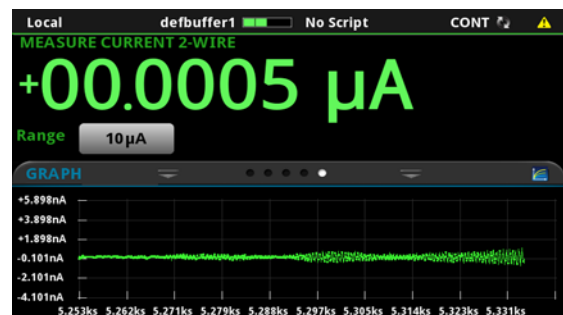

Pin 2 to 1, Bias=3.7V

## ◆ Condition 6

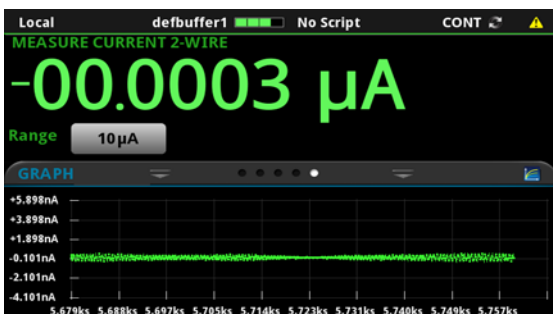

Pin 1 to 2, Bias=3.8V

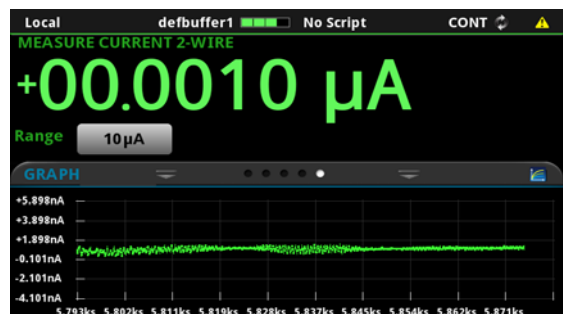

Pin 2 to 1, Bias=3.8V



Transmission Line Pulse (TLP) is a measurement technique used in the Electrostatic Discharge (ESD) arena to characterize performance attributes of devices under ESD stresses. TLP is able to obtain current versus voltage (I-V) curves in which each data point is obtained with a 100 ns long pulse, with currents up to 40 A. TLP was first used in the ESD field to study human body model (HBM) in integrated circuits, but it is an equally valid tool in the field of system level ESD. The applicability of TLP to system level ESD is illustrated in Figure 1, which compares an 8 kV IEC 61000-4-2 current waveform with TLP current pulses of 8 and 16 A. The current levels and time duration for the pulses are similar and the initial rise time for the TLP pulse is comparable to the rise time of the IEC 61000-4-2's initial current spike. This application note will give a basic introduction to TLP measurements and explain the datasheet parameters extracted from TLP for

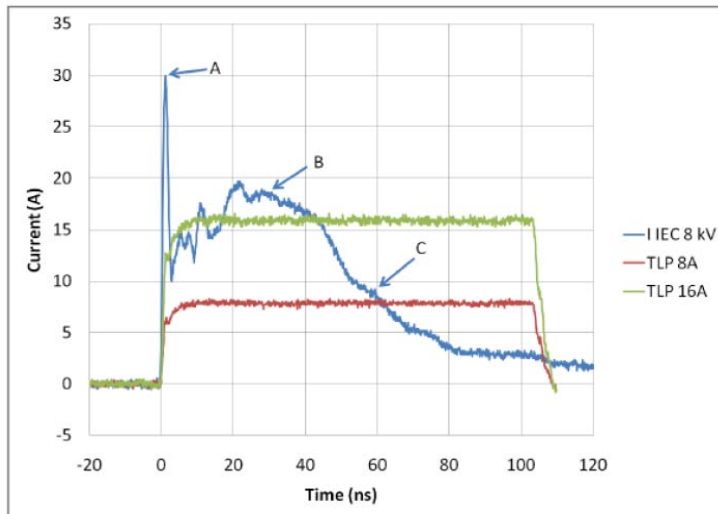

Comparison of a Current Waveform of IEC 61000-4-2 with TLP Pulses at 8 and 16 A.

The IEC 61000-4-2 ESD waveforms is true to the Standard and is shown here as captured on an oscilloscope. The points A, B, and C show the points on the waveforms specified in IEC 61000-4-2.

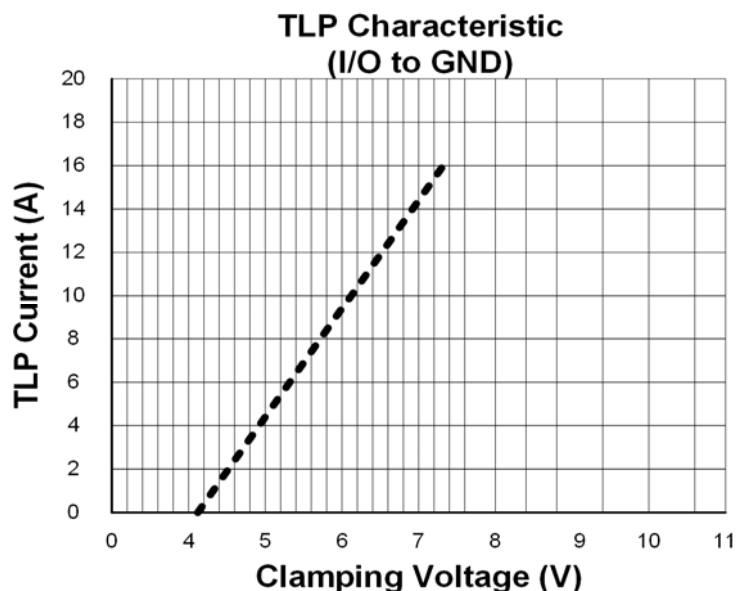

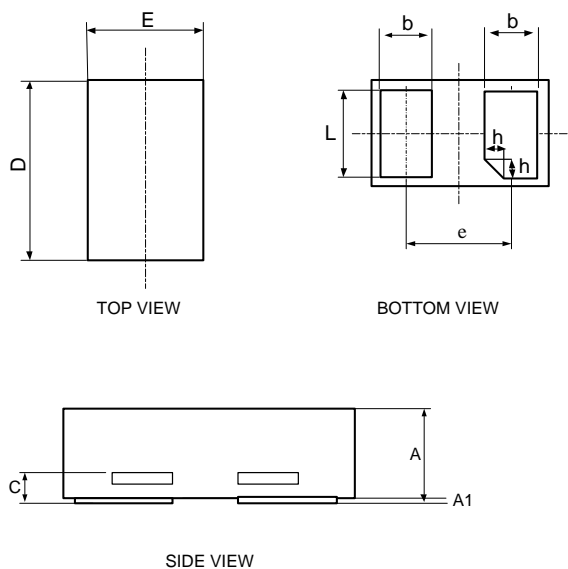

Symbol	Dimensions in millimeters		
	Min	Nom	Max
A	0.28	0.30	0.32
A1	0.00	0.02	0.05
C	0.05	0.10	0.15
D	0.55	0.60	0.65
E	0.25	0.30	0.35
e	0.34	0.35	0.37
b	0.14	0.19	0.24
L	0.20	0.25	0.30
h	0	0.05	0.10

## Ordering information

Order code	Package	Base qty	Delivery mode
RHTVSBC0321-T	DFN0603	12k	Tape and reel