



RHONDA SEMICONDUCTOR CO.,LTD

PART NO. ESD0402-V05

1.1 Technology Data

	Symbol		Value	Unit
Maximum allowable continuous AC voltage at 50-60Hz	V_{RMS}		---	V
Maximum allowable continuous DC voltage	V_{DC}		5	V
Typical capacitance value measured at 1MHz	C		5	pF
Typical capacitance value tolerance	C		± 1	pF
Typical ESD trigger Voltage	V_T		25	V
Typical ESD clamping Voltage after 30ns	V_C		12	V
Leakage current at V_{DC} (At initial state)	I_{LDC}	<	0.05	uA
Leakage current at V_{DC} (After ESD Test)	I_{LDCA}	<	1	uA

1.2 Reference Data

Response time	T_{rise}	<	1	ns
Operation ambient temperature			-50~ +85	°C
Storage temperature			-50~+125	°C
ESD testing	IEC61000-4-2		level 4	

1.3 Other Data

Body			High molecular polymer	
End termination			Ag/Ni/Sn	
Packaging			Reel	
Complies with Standard			IEC61000-4-2	
Complies with RoHs Standard			Yes	
Lead Content		<	100	ppm
Marking			None	

Notes : ESD voltage capability(tested per IEC 61000-4-2).

- Contact discharge mode:typical 8kV,max 15kV
- Air discharge mode:typical 15kV,max 25kV

Part No. :	ESD0402-V05	Document No.	ESD-RD0402ME2010	REV.	D3
-------------------	-------------	---------------------	------------------	-------------	----

2 .Size

Model	0402(1005)	0603(1608)
Length(L)	1.00 ±0.10	1.60±0.15
Width(W)	0.50 ±0.10	0.80±0.10
Thickness(T)	0.60 max	0.90 max
Termination(a)	0.25±0.1	0.3±0.1

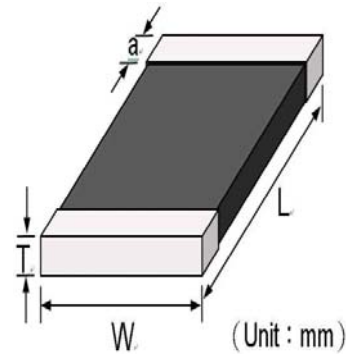

3. ESD Wave Form

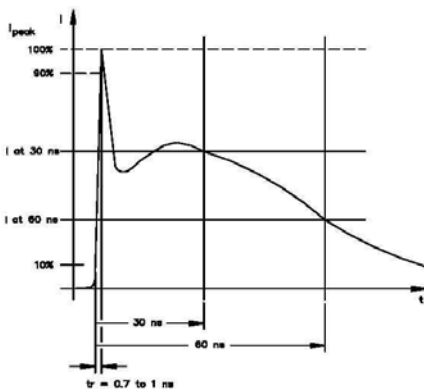

IEC61000-4-2 Standards

SEVERITY LEVEL	AIRDIRCHARGE	DIRECT DISCHARGE
1	2 KV	2 KV
2	4 KV	4 KV
3	8 KV	6 KV
4	15 KV	8 KV

IEC 61000-4-2 Compliant ESD Current Pulse Waveform

4. Environment Reliability Test

Characteristic	Test method and description			
High Temperature Storage	The specimen shall be subjected to 125 ± 2°C for 1000 ± 12 hours in a thermostatic bath without load and then stored at room temperature and normal humidity for 1 to 2 hours. The change of breakage voltage shall be within 10 % .			
Temperature Cycle	The temperature cycle of specified temperature shall be repeated five times and then stored at room temperature and normal humidity for one or two hours. The change of breakage voltage shall be within 10 % and mechanical damage shall be examined.	Step	Temperature	Period
		1	-40±3°C	30Min±3
		2	Room Temperature	1 hour
		3	125±3°C	30Min±3
4	Room Temperature	1 hour		
High Temperature Load	After being continuously applied the maximum allowable voltage at 85 ± 2°C for 1000± 2 hours, the specimen shall be stored at room temperature and normal humidity for one or two hours, the change of breakage voltage shall be within 10% .			
Damp Heat Load/ Humidity Load	The specimen should be subjected to 40 ± 2°C , 90 to 95 % RH environment, and the maximum allowable voltage applied for 1000 hours, then stored at room temperature and normal humidity for one or two hours. The change of breakage voltage shall be within 10%			
Low Temperature Storage	The specimen should be subjected to -40 ± 2°C , without load for 500 hours and then stored at room temperature for one or two hours. The change of breakage voltage shall be within 10 %			

Part No. :	ESD0402-V05	Document No.	ESD-RD0402ME2010	REV.	D3
-------------------	-------------	---------------------	------------------	-------------	----

5. Soldering Recommendations

5.1 Recommended solder pad layout

(Unit : mm)

	A	B	C	D
0402	0.4~0.6	1.4~1.8	0.5~0.6	0.6~1.2
0603	0.9~1.2	2.7~3.2	0.7~1.0	0.9~1.2

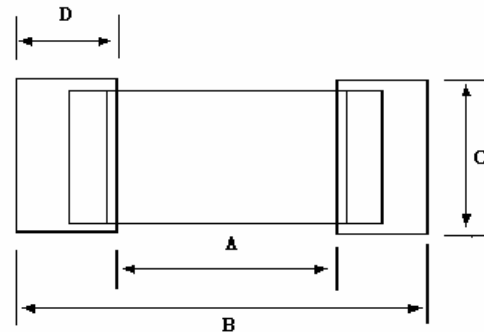

5.2 The SIR test of the solder paste shall be done (Based on JIS-Z-3284)

5.3 Steel plate and foot distance printing

Foot distance printing (mm)	Steel Plate thickness (mm)
> 0.65mm	0.18mm
0.65mm~0.5mm	0.15mm
0.50mm~0.40mm	0.12mm
>=0.40 mm	0.10mm

5.4 The IR reflow and temperature of Soldering for Pb Free

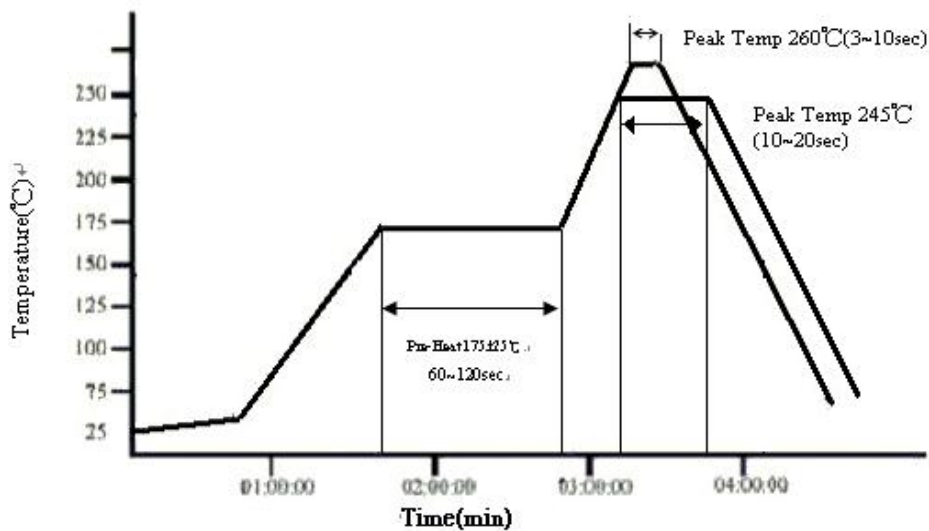

☆ IR reflow Pb Free Process suggestion profile

- (1) The solder recommend is Sn96.5/Ag 3.5 of 120 to 150 μm
- (2) Ramp-up rate (217°C to Peak) + 3°C/second max
- (3) Temp. maintain at 175 +/-25°C 180 seconds max

Part No. :	ESD0402-V05	Document No.	ESD-RD0402ME2010	REV.	D3
-------------------	-------------	---------------------	------------------	-------------	----



- (4) Temp. maintain above 217 °C 60-150 seconds
- (5) Peak temperature range 245°C +20°C/ -10 °C time within 5 °C of actually peak temperature (tp) 10~20 seconds
- (6) Ramp down rate +6 °C/second max.

※Perform adequate test in advance as the reflow temperature profile will vary according to the conditions of the manufacturing process, and the specification of the reflow furnace.

5.5 Resistance to soldering heat-High Temperature Resistance:260°C ,10sec-3times.

5.6 Hand Soldering

In hand soldering of the ESD devices. Large temperature gradient between preheated the ESD devices and the tip of soldering iron may cause electrical failures and mechanical damages such as crackings or breakings of the devices. The soldering shall be carefully controlled and carried out so that the temperature gradient is kept minimum with following recommended conditions for hand soldering.

5.6.1 Recommended Soldering Condition 1

- (1) Solder :
0.12~0.18mm Thread solder (Sn96.5:Ag3.5) with soldering flux in the core.
Rosin-based and non-activated flux is recommended.
- (2) Preheating
The shall be preheated so that Temperature Gradient between the devices and the tip of soldering iron is 150°C or below.
- (3) Soldering Iron
Rated Power of 20w max with 3mm soldering tip in diameter.
Temperature of soldering iron tip 380°C max,3-5sec (The required amount of solder shall be melted in advance on the soldering tip.)
- (4) Cooling
After soldering. The ESD devices shall be cooled gradually at room ambient temperature.

5.6.2 Recommended Soldering Condition 2 (Without preheating)

- (1) Solder iron tip shall not directly touch to ceramic dielectrics.
- (2) Solder iron tip shall be fully preheated before soldering while soldering iron tip to the external electrode of ESD devices .

5.7 Post Soldering Cleaning

5.7.1 Residues of corrosive soldering fluxes on the PC board after cleaning may greatly have influences on the electrical characteristic and the reliability (such as humidity resistance)of the ESD devices which have been mounted on the board. It shall be confirmed that the characteristic and the reliability of the devices are not affected by the applied cleaning conditions.

5.7.2. When an ultrasonic cleaning is applied to the mounted ESD devices on PC Boards. Following conditions are recommended for preventing failures or damages of the devices due to the large vibration energy and the resonance caused by the ultrasonic waves.

- (1) Frequency 29MHz max

Part No. :	ESD0402-V05	Document No.	ESD-RD0402ME2010	REV.	D3
-------------------	-------------	---------------------	------------------	-------------	----

- (2) Radiated Power 20w/lithr max
- (3) Period 5minuets max

6. Packaging Specification

- 6.1 Carrier tape and transparent cover tape should be heat-sealed to carry the products, and the reel should be used to reel the carrier tape.
- 6.2 The adhesion of the heat-sealed cover tape shall be 40 + 20/ - 15grams.
- 6.3 Both the head and the end portion of the taping shall be empty for reel package and SMT auto-pickup machine. And a normal paper tape shall be connected in the head of taping for the operator to handle.

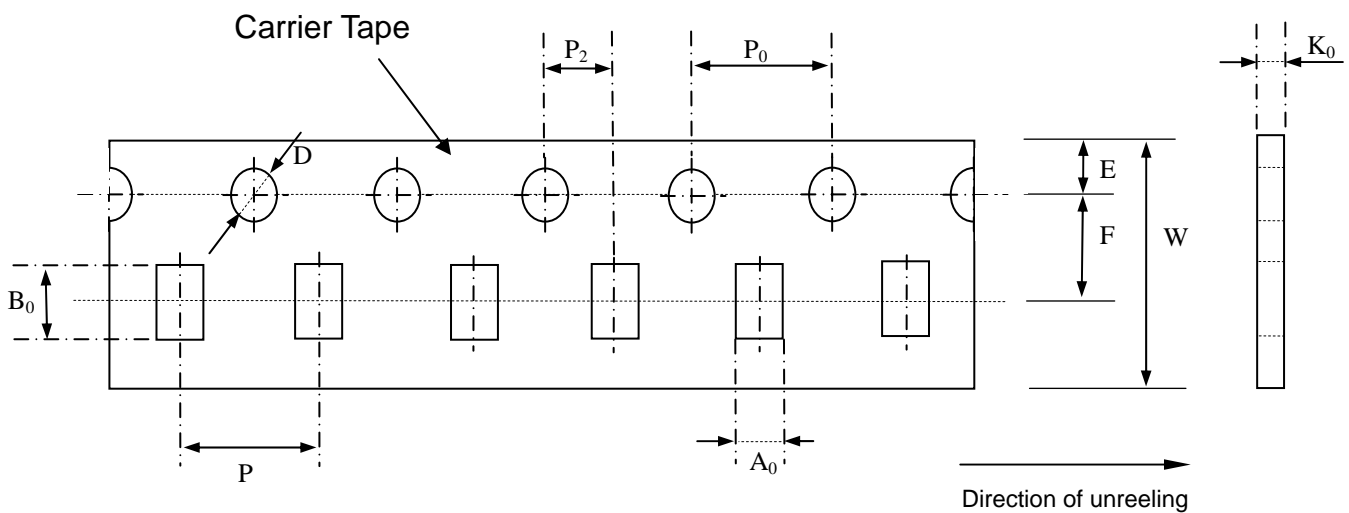

Symbol	A ₀ ±0.05	B ₀ ±0.05	K ₀ ±0.05	D +0.10 -0.05	P ±0.10	P ₂ ±0.10	P ₀ ±0.10	W ±0.10	E ±0.10	F ±0.05
0402	0.62	1.12	0.60	1.55	2.00	2.00	4.00	8.00	1.75	3.50
0603	1.10	1.90	0.95	1.56	4.00	2.00	4.00	8.00	1.75	3.50

Part No. :	ESD0402-V05	Document No.	ESD-RD0402ME2010	REV.	D3
-------------------	-------------	---------------------	------------------	-------------	----



(4) temp. maintain above 217 °C 60-150 seconds

7.Reel Dimension

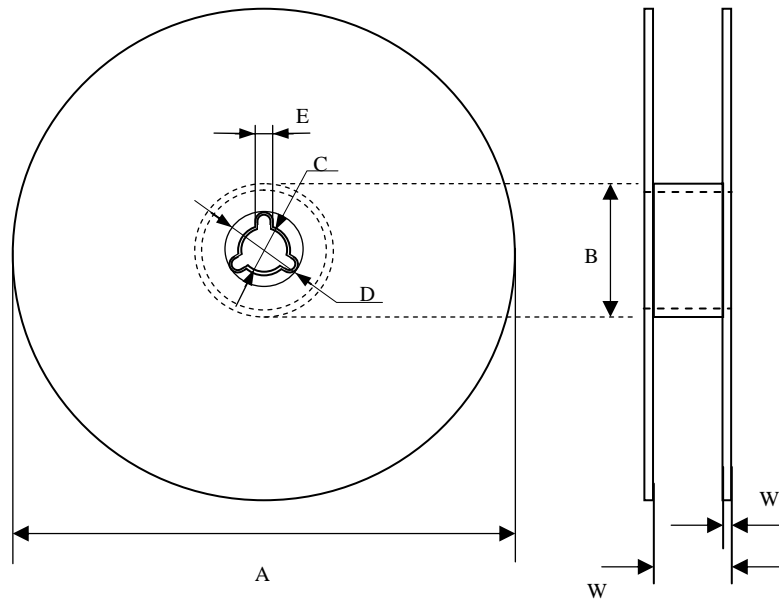

Symbol	A	B	C	D	E	W	W ₁
0402	178.0±1.0	60.0±0.5	13.0±0.2	21.0±0.2	2.0±0.5	9.0±0.50	1.5±0.15
0603	178.0±1.0	60.0±0.5	13.0±0.2	21.0±0.2	2.0±0.5	9.0±0.50	1.5±0.15

8.Standard Packaging

Size	0402	0603
Pcs	10000	4000/5000

Part No. :	ESD0402-V05	Document No.	ESD-RD0402ME2010	REV.	D3
-------------------	-------------	---------------------	------------------	-------------	----